

EC8094 SATELLITE COMMUNICATION

QUESTION BANK

UNIT I SATELLITE ORBITS	
Kepler's Laws, Newton's law, orbital parameters, orbital perturbations, station keeping, Geo stationary and non-Geo-stationary orbits – Look Angle Determination- Limits of visibility – eclipse-Sub satellite point –Sun transit outage-Launching Procedures - launch vehicles and propulsion.	
UNIT-I / PART-A	
1	What is Satellite? An artificial body that is projected from earth to orbit of solar systems. Types: Information satellites and Communication Satellites.
2	What is the limit of visibility? (Nov/Dec 2016) The east and west limits on the geostationary arc of a satellite which are visible from any given earth station are known as limits of visibility.
3	State Kepler's first law. (Nov/Dec 2016) (Apr/May 2017) It states that the path followed by the satellite around the primary will be an ellipse. An ellipse has two focal points F_1 and F_2 . The center of mass of the two-body system, termed the barycenter is always centered on one of the foci. $e = (\sqrt{a^2 - b^2})/a$
4	State Kepler's second law. (Apr/May 2015) It states that for equal time intervals, the satellite will sweep out equal areas in its orbital plane, focused at the bary center.
5	State Kepler's third law. (Nov/Dec 2018) Kepler's third law states that the square of the periodic time of orbit is proportional to the cube of the mean distance between the two bodies. The mean distance is equal to the semi major axis a . For the artificial satellites orbiting the earth, Kepler's third law can be written in the form $a^3 = \mu/n^2$ Where 'n' is the mean motion of the satellite in radians per second and the earth's geocentric gravitational constant is given by $\mu = 3.986005 \times 10^{14} \text{ m}^3/\text{s}^2$
6	Define apogee. (Nov/Dec 2019) It is defined as the point farthest from the earth
7	Define Perigee. (Nov/Dec 2019) It is defined as the point closest from the earth.
8	What are the geostationary satellites? (Apr/May 2014) The satellites present in the geostationary orbit are called geostationary satellite. The geostationary orbit is one in which the satellite appears stationary relative to the earth. It lies in equatorial plane and inclination is '0°'. The satellite must orbit the earth in the same direction as the earth spin. The orbit is circular.
9	Differentiate geostationary and geosynchronous satellite. (Nov/Dec 2013) (Apr/May 2021) A geosynchronous satellite is a satellite whose orbital track on the earth repeats regularly over points on the earth over time. If such a satellite's orbit lies over the equator and the orbit is circular, it is called geostationary satellite.

10	Define ascending node. (Nov/Dec 2014) It is defined as the point where the orbit crosses the equatorial plane going from south to north.
11	Define descending node. (Nov/Dec 2014) It is defined as the point where the orbit crosses the equatorial plane going from north to south.
12	Define mean anomaly. It is defined as an average value of the angular position of the satellite with reference to the perigee.
13	Define true anomaly. It is defined as the angle from perigee to the satellite position, measured at the earth's center.
14	Mention the apogee and perigee height. Apogee (A) means the furthest distance a satellite gets from Earth in its orbit. A is related to the semi-major axis and eccentricity. $A=a(1+e)$. Perigee (P) means the closest distance the satellite gets to Earth in its orbit. P is related to the semi-major axis and eccentricity $P=a(1-e)$.
15	Identify the basic factors affecting satellite position. (Apr/May 2016) The basic factors affecting satellite position are Elevation Angle, Coverage Angle, Free Space Loss & Atmospheric Attenuation.
16	The limit of visibility depends on what factors? Considering an earth station at the equator, with the antenna pointing either west or east along the horizontal calculate the limiting angle. (Apr/May 2016) Any geostationary satellite has an arc of visibility which can also be called footprint. This depends upon the height of satellite, elevation angle and area of coverage. The limiting angle = $\arccos(\alpha_E/\alpha_{GSO}) = \arccos(6378 / 42164) = 81.3^\circ$.
17	Write short notes on station keeping. (Apr/May 2016) It is the process of maintenance of satellite's attitude against different factors that can cause drift with time. Satellites need to have their orbits adjusted from time to time, because the satellite is initially placed in the correct orbit, natural forces induce a progressive drift.
18	What is look angle? The azimuth and elevation angles of the ground station antenna are termed as look angles.
19	Write short notes on station keeping. (Apr/May 2016) It is the process of maintenance of satellite's attitude against different factors that can cause drift with time. Satellites need to have their orbits adjusted from time to time, because the satellite is initially placed in the correct orbit, natural forces induce a progressive drift.
20	Which parameters decide the system reliability? (Apr/May 2015) Overall reliability of a satellite is governed by the reliability of its critical space crafts components.
21	A satellite moving is orbiting in the equatorial plane with a period from period

	<p>from perigee to perigee of 12hrs. Given the eccentricity is 0.02. Calculate the semi-major axis. The earth's equatorial radius is 6378.1414 km. (Nov/Dec 2013)</p> <p>Given $e=0.02$ $\mu=3.986005 \times 10^{14}$ $a_E=6378.1414 \text{ km}$ Mean motion $n=2\pi/p=2\pi/12=1.454 \times 10^{-4} \text{ s}^{-1}$ $a=(\mu/n^2)^{1/3}=26610 \text{ km}.$</p>										
22	<p>Differentiate ascending node from descending node. (Apr/May 2015)</p> <p>In ascending node, the point at which the orbit crosses the equatorial plane goes from south to north. In descending node, the point at which the orbit crosses the equatorial plane goes from north to south.</p>										
23	<p>Find the viewing angle of a geostationary satellite orbiting at 42000km from an earth station making an elevation angle of 25 degrees. (Nov/Dec 2014)</p> $d = \sqrt{R^2 + a_{GSO}^2 - 2Ra_{GSO} \cos b}$ $= \sqrt{42000^2 + 42164^2 - 2 \times 42000 \times 42164 \times \cos 25^\circ}$ $= 18217 \text{ Km}$ $EI = \arccos\left(\frac{a_{GSO}}{d} \sin b\right) = \arccos\left(\frac{42164}{18217} \sin 25^\circ\right) = 12^\circ$										
24	<p>List the differences between LEO and MEO satellites. (Nov/Dec 2014)</p> <table border="1" style="width: 100%; border-collapse: collapse;"> <thead> <tr> <th style="width: 50%; text-align: center;">LEO</th> <th style="width: 50%; text-align: center;">MEO</th> </tr> </thead> <tbody> <tr> <td>LEO stands for Low Earth Orbit</td> <td>MEO stands for Middle Earth Orbit</td> </tr> <tr> <td>LEO satellite range is 500 to 1500 km</td> <td>MEO satellite range is 8000 to 18000 km</td> </tr> <tr> <td>Smaller area of coverage</td> <td>Larger coverage area</td> </tr> <tr> <td>Visible for 15 to 20 minutes</td> <td>Visible for 2 to 8 hours</td> </tr> </tbody> </table>	LEO	MEO	LEO stands for Low Earth Orbit	MEO stands for Middle Earth Orbit	LEO satellite range is 500 to 1500 km	MEO satellite range is 8000 to 18000 km	Smaller area of coverage	Larger coverage area	Visible for 15 to 20 minutes	Visible for 2 to 8 hours
LEO	MEO										
LEO stands for Low Earth Orbit	MEO stands for Middle Earth Orbit										
LEO satellite range is 500 to 1500 km	MEO satellite range is 8000 to 18000 km										
Smaller area of coverage	Larger coverage area										
Visible for 15 to 20 minutes	Visible for 2 to 8 hours										
25	<p>What are the features of LEO? (Apr/May 2015)</p> <p>Low Earth orbit (LEO) is an orbit around Earth with an altitude between 160 kilometers and 2,000 kilometers. A low Earth orbit is simplest and cheapest for satellite placement. It provides high bandwidth and low communication time lag (latency), but satellites in LEO will not be visible from any given point on the Earth at all times.</p>										
26	<p>Define orbital period. (Apr/May 2017)</p> <p>It is defined as the time it takes to complete one full orbit around a celestial body and it also depends on the altitude of the satellite</p> <p>Kepler's third law relates the period and the radius of objects in orbit around a star or planet. In conjunction with Newton's law of universal gravitation, giving the attractive force between two masses, we can find the speed and period of an artificial satellite in orbit around the Earth.</p>										
27	<p>What is prograde orbit direct orbit? (Nov/Dec 2019)</p> <p>An orbit in which satellite moves in the same direction as the Earth's rotation. Its inclination is always between 0° to 90°. Many satellites follow this path as Earth's</p>										

	velocity makes it easier to launch these satellites.																			
28	<p>What is a geostationary orbit? (Nov/Dec 2017) A geostationary orbit is one in which a satellite orbits the earth at exactly the same speed as the earth turns and at the same latitude, specifically zero, the latitude of the equator. A satellite orbiting in a geostationary orbit appears to be hovering in the same spot in the sky which is directly over the same patch of ground stations at all times.</p>																			
29	<p>Distinguish between LEO system and GEO system. (Nov/Dec 2018)</p> <table border="1"> <tr> <td>Orbital period</td> <td>24 hours</td> <td>10 to 40 minutes</td> </tr> <tr> <td>Satellite height</td> <td>35,800 km</td> <td>500 to 1500 km</td> </tr> <tr> <td>Propagation loss</td> <td>Highest</td> <td>least</td> </tr> <tr> <td>Advantages</td> <td>Covers large geographical area, only three GEO satellites are needed to cover earth</td> <td>LEO satellite provides better signal strength. It has least signal propagation delay since it is closest to earth.</td> </tr> <tr> <td>Disadvantages</td> <td>Considerable time delay in the signal, which is not favorable for point to point communication.</td> <td>Very costly, Atmospheric drag effects are more which cause gradual orbital disorientation</td> </tr> <tr> <td>Orbital period</td> <td>24 hours</td> <td>10 to 40 minutes</td> </tr> </table>		Orbital period	24 hours	10 to 40 minutes	Satellite height	35,800 km	500 to 1500 km	Propagation loss	Highest	least	Advantages	Covers large geographical area, only three GEO satellites are needed to cover earth	LEO satellite provides better signal strength. It has least signal propagation delay since it is closest to earth.	Disadvantages	Considerable time delay in the signal, which is not favorable for point to point communication.	Very costly, Atmospheric drag effects are more which cause gradual orbital disorientation	Orbital period	24 hours	10 to 40 minutes
Orbital period	24 hours	10 to 40 minutes																		
Satellite height	35,800 km	500 to 1500 km																		
Propagation loss	Highest	least																		
Advantages	Covers large geographical area, only three GEO satellites are needed to cover earth	LEO satellite provides better signal strength. It has least signal propagation delay since it is closest to earth.																		
Disadvantages	Considerable time delay in the signal, which is not favorable for point to point communication.	Very costly, Atmospheric drag effects are more which cause gradual orbital disorientation																		
Orbital period	24 hours	10 to 40 minutes																		
30	<p>Name the Keplerian element set. (Apr/May 2018) The six Keplerian elements are: Eccentricity (e), Semi major axis(a), Mean anomaly (Mo), Argument of perigee (ω), Inclination (i), Right ascension (Ω).</p>																			
31	<p>What is meant by sun transit outage? (Apr/May 2018) Sun transit outage is an interruption in, or distortion of geostationary satellite signals caused by interference from solar radiation. Sun appears to be an extremely noisy source which completely blanks out the signal from satellite. This effect lasts for 6 days around the equinoxes. They occur for a maximum period of 10 minutes.</p>																			
32	<p>A satellite is in an elliptical orbit with eccentricity of 0.6 and perigee altitude 1000 Km. Determine: a) The semi major axis b) The period of revolution (Apr/May 2021) Given: eccentricity (e) = 0.6; perigee (R_p) = 1000 $R_p = a(1-e)$ $1000 = a(1-0.6) \Rightarrow a$ (semi major axis) = 2500 Km. By Kepler's law; period of revolution $T^2 = a^3 \Rightarrow T = 125000$ Sec.</p>																			
33	<p>Assume a circular orbit: Using Newton's law of gravitation and Newton's second law, determine the acceleration of a satellite. (Apr/May 2021) By Newton's second law of motion $F = ma$ (1) By Newton's law of gravitation $F = GmM/r^2$ (2) Equating equation (1) & (2) $\Rightarrow a = Gm/r^2$</p>																			

UNIT-I / PART-B - (C410.1)	
1	Explain how Keplers's and Newton's law are used to describe the orbit. Explain about satellite launch vehicles. (Nov/Dec 2019)
2	Describe the terms of earth orbiting satellites. (Apr/May 2016)
3	(a) Define look angle and explain look angle determination in detail. (b) If a satellite is at a height of 36000 km and orbiting in equatorial plane, comment whether the satellite will be under eclipse on equinox days and find the duration of the eclipse. (Nov/Dec 2014)
4	(a) Describe the steps involved in launching a satellite. (Apr/May 2016), (Apr/May 2015) & (Nov/Dec2014) . (b) What are the different types of satellite orbits? Discuss their merits and demerits. (Nov/Dec 2014) (Apr/May 2017) .
5	A satellite in polar orbit has a perigee height of 600 km and an apogee height of 1200 km. Calculate the mean motion and the rate of regression of the nodes. Assume the polar radius of the earth to be equal to 6357 kms. (Apr/May 2016)
6	(i) State and Explain Kepler's three laws of motion with suitable diagrams. (April /May 2018) (ii) A satellite is orbiting in the equatorial plane with a period from perigee to perigee of 12 h. Given that the Eccentricity is 0.002. Calculate the semi major axis. The earth's equatorial radius is 6378.1414km. (iii) Write a brief note on Atmospheric drag. (Apr/May 2015). (April /May 2018)
7	Determine the limits of visibility for an earth station situated at mean sea level, at a latitude 48.42° north and longitude 89.26° west. Assume a minimum angle of elevation 5°. (Apr/May 2015)
8	(i) Illustrate the orbital parameters used for positioning a satellite. (Nov/Dec 2016) (ii) Estimate the suitable equations for look angles and the range for geostationary satellite. (Nov/Dec 2016)
9	Derive the equation for a satellite orbit. (Apr/May 2017)
10	Derive the equations which permit the elevation angle to be calculated. (Apr/May 2017)
11	State and explain the parameters for Earth orbiting satellites. (Nov/Dec 2017)
12	Describe in detail the launching procedure of a satellite. (Nov/Dec 2017)
13	What is the principle Liquid Propulsion System? Explain the specific technologies under the category of Electric and ion propulsion. (Nov/Dec 2018)
14	Explain the features of typical satellite launch vehicles. (Nov/Dec 2018)
15	(i) Draw and explain the geometry for determining the sub satellite point. (ii) Explain and illustrate the limits of visibility in satellite orbits. (April /May 2018)
16	i) Explain the orbital perturbations. ii) What is meant by the geo stationary orbit and also explain the conditions to be required for an orbit to be geo stationary? (Nov/Dec 2019)
17	Derive the complete expression for Look Angles, along with intermediate angle in satellite communication. Show that intermediate angle is : (Apr/May 2021) $\alpha = \tan^{-1} \left[\frac{\tan l_s - l_e }{\sin L_e} \right]$

18	A satellite is in a circular orbit around the earth. The altitude of the satellite's orbit above the surface of the earth is 1400 Km. i) What are the centripetal and centrifugal accelerations acting on the satellite in its orbit? Give your answer in m/s^2 ii) What is the velocity of the satellite in this orbit? Give your answer in km/s. iii) What is the orbital period of the satellite in this orbit? Give your answer in hours, minutes and seconds. (Apr/May 2021)
19	The state of Virginia may be represented roughly as a rectangle bounded by 39.5° N latitude on the north, 36.5° N latitude on the south, 76.0° W longitude on the east and 86.3° W longitude on the west. If a geostationary satellite must be visible throughout virginia at an elevation angle no lower than 20° , what is the range of longitudes within which the sub-satellite point of the satellite must lie? (Apr/May 2021)
20	A ground station lies at latitude = 39.2906 degrees N and longitude = 280.2629 degrees E. A Geostationary satellite at radius $r = 42164$ km has a longitude of 280.2629 degrees E. Calculate the range and look angles (azimuth and elevation angles) to the satellite? (Apr/May 2021)

UNIT II SPACE SEGMENT

Spacecraft Technology- Structure, Primary power, Attitude and Orbit control, Thermal control and Propulsion, communication Payload and supporting subsystems, Telemetry, Tracking and command-Transponders-the Antenna Subsystem.

UNIT-II / PART-A

1	Give the two segments of basic satellite communication. a. Earth segment (or) ground segment b. Space segment
2	Write short notes on altitude control system. It is the system that achieves and maintains the required attitudes. The main functions of attitude control system include maintaining accurate satellite position throughout the life span of the system.
3	What is declination? The angle of tilt is often referred to as the declination which must not be confused with the magnetic declination used in correcting compass readings.
4	Formulate uplink and downlink equation of a satellite access (Nov/Dec 2016) Uplink Equation $\left[\frac{C}{N_o}\right]_U = [EIRP]_U - [BO]_i - [LOSSES]_U + \left[\frac{G_R}{T_S}\right]_U - [K]$ Downlink Equation $\left[\frac{C}{N_o}\right]_D = [EIRP]_D - [BO]_o - [LOSSES]_D + \left[\frac{G_R}{T_S}\right]_D - [K]$
5	Define payload and transponder? (Apr/May 2021) Payloads in satellites are the scientific instruments carried by that satellite. A satellite can have multiple payloads for different type of operations in space. In a communication satellite, the equipment which provides the connecting link between the satellite's transmit and receive antennas is referred to as the transponder.
6	Why should an omnidirectional antenna be used aboard a satellite for telemetry and command during the launch phase? (Apr/May 2016)

	<p>Certain frequencies have been designated by international agreement for satellite telemetry transmissions. During the transfer and drift orbital phases of the satellite launch, a special channel is used along with an omnidirectional antenna. Once the satellite is on station, one of the normal communications transponders may be used along with its directional antenna, unless some emergency arises which makes it necessary to switch back to the special channel used during the transfer orbit.</p>
7	<p>What is meant by Pitch angle? Pitch angle is the degree of elevation or depression. Movement of a spacecraft about an axis which is perpendicular to its longitudinal axis.</p>
8	<p>What is a propellant? Propellant is a solid or liquid substance burnt in a rocket for the purpose of producing thrust.</p>
9	<p>What is Yaw? Yaw is the rotation of a vehicle about its vertical axis.</p>
10	<p>What is an zero 'g'? Zero 'g' is a state when the gravitational attraction is opposed by equal and opposite inertial forces and the body experiences no mechanical stress.</p>
11	<p>Write short notes on the spin stabilized satellites. In a spin stabilized satellites, the body of the satellite spins at about 30 to 100 rpm about the axis perpendicular to the orbital plane. The satellites are normally dual spin satellites with a spinning section and a despun section on which antennas are mounted. These are kept stationary with respect to earth by counter rotating the despun section.</p>
12	<p>Mention about the functions of AOCs. (Nov/Dec 2013) The Aeronautical Operational Control (AOC) communications is the operational facility in which the Air Component Commander (ACC) has centralized the functions of planning, direction, and control over deployed air resources.</p>
13	<p>What is meant by momentum wheel stabilization? During the spin stabilization, flywheels may be used rather than spinning the satellite. These flywheels are termed as momentum wheels.</p>
14	<p>Define sky noise. Sky noise is a term used to describe the microwave radiation which is present throughout universe and which appears to originate from matter in any form, at finite temperature.</p>
15	<p>What is the function of Telemetry Tracking and Command (TT&C)? Telemetry, tracking, and command is used for communication between spacecraft and the ground systems. The subsystem functions are: Controlling of spacecraft by the operator on earth. Receive the uplink commands, process and send them to other subsystems for implication. The purpose of TT& C function is to ensure the satellite performs correctly.</p>
16	<p>Examine why noise temperature is a useful concept in communication receiver (Nov/Dec 2016) Noise temperature is a measure of the noise entering a receiver through antenna. Noise</p>

	<p>temperature provides a way of determining how much thermal noise is generated by active and passive devices in the receiving system.</p> <p>Generally, at the receiver side, the noise temperature should be maintained as low as possible, Front-end amplifier is immersed in liquid helium to maintain its physical temperature around 4 K. It is practiced in large earth stations.</p>			
17	<p>What is noise weighting? The method used to improve the post detection signal to noise ratio is referred to as noise weighting.</p>			
18	<p>What is an OMT? The polarization separation takes place in a device known as an orthocoupler or Orthogonal Mode Transducer (OMT).</p>			
19	<p>A satellite downlink at 12 GHz operates with a transmit power of 6W and an antenna gain of 48.2dB. Calculate the EIRP in dBW. (Nov/Dec 2017) EIRP = 10 log (6w/1w) +48.2 = 56dBW</p>			
20	<p>What is split body stabilization? (Nov/Dec 2014) The body of the satellite remains fixed to the earth so the 3-axis stabilization is also referred to as split body stabilization.</p>			
21	<p>Write the objective with the downlink of any satellite communication system must be designed. (Apr/May 2014)</p> <p>(i) To guarantee the continuity of the link for a specified percentage of the time with the given S/N</p> <p>(ii) To carry the maximum number of channels at a minimum capital and maintenance cost.</p>			
22	<p>How do you characterize uplink and downlink? (Apr/May 2017) Two frequencies are necessary for communication between a ground station and a satellite; one for communication from the ground station on the earth to the satellite called uplink frequency and another frequency for communication from the satellite to a station on the earth, called downlink frequency. These frequencies, reserved for satellite communication, are divided in several bands such as L, S, Ku, etc are in the gigahertz (microwave) frequency range as shown in Table. Higher the frequency, higher is the available bandwidth.</p>			
	Band	Downlink Frequency (GHz)	Uplink Frequency (GHz)	Bandwidth (MHz)
	L	1.5	1.6	15
	S	1.9	2.2	70
	C	4	6	500
	Ku	11	14	500

	Ka	20	30	3500
23	<p>What is the need for thermal control and propulsion? ((Nov/Dec 2013) & (Apr/May 2015))</p> <p>The use of thermal control is to operate the satellite in temperature stable environment A solid or liquid substance burnt in a rocket for the purpose of producing thrust.</p>			
24	<p>What are the effects to which the displacement in association with tracking feeds gives rise? (Apr/May 2017)</p> <p>The problem of making a tracking feed can best be understood by considering the field in the focal region of a paraboloid when a satellite beacon transmitter is slightly off axis. The focal plane distribution will be unchanged in form, but displaced from the horn axis and the direction of displacement in angle corresponds to the position of the satellite. The displacement gives rise to three effects.</p> <p>1.The additional asymmetric waveguide modes are used to detect and extract information of tracking.2. The energy contained within the main lobe of focal plane distribution fails to enter the horn that can be detected by additional horns outside the main horns.3.The reduction in gain can be detected.</p>			
25	<p>Why is thermal control necessary in a satellite? (Nov/Dec 2017)</p> <p>Thermal control is absolutely essential for both the physical integrity of the satellite and for its efficient operation because electronic equipment have their optimum performance within a certain temperature range.</p> <p>Thermal control is essential to guarantee the optimum performance and success of the mission because if a component is subjected to temperatures which are too high or too low, it could be damaged, or its performance could be severely affected. Thermal control is also necessary to keep specific components (such as optical sensors, atomic clocks, etc.) within a specified temperature stability requirement, to ensure that they perform as efficiently as possible.</p>			
26	<p>Why is the satellite link probably the most basic in microwave communications? (Nov/Dec 2018)</p> <p>Microwave frequencies are used in satellite communication because they require line of sight between the sender and receiver which is not possible in terrestrial communication links. As a result, the satellites can cover large distances compared to terrestrial links.</p>			
27	<p>Write the relationship between EIRP and antenna gain? (Nov/Dec 2018)</p> <p>The relationship between EIRP and antenna gain is $EIRP = P_t * G_t$ P_t- transmit power; G_t- transmit antenna gain.</p>			
28	<p>What is the use of frequency reuse technique in communication subsystem and how it is employed? (April/May 2018)</p> <p>The satellite as a whole to be accessed by earth stations widely separated geographically but transmitting on the same frequency that is known as frequency reuse. It can be implemented by Space Division Multiple Access (SDMA).</p>			
29	<p>Give the formula for reliability of hardware. (April/May 2018) (Nov/Dec 2019)</p> <p>Reliability of hardware is given by $R(t) = e^{-\lambda t}$ where λ- failure rate.</p>			
30	<p>What does the term 'bus' refer in TT & C?</p>			

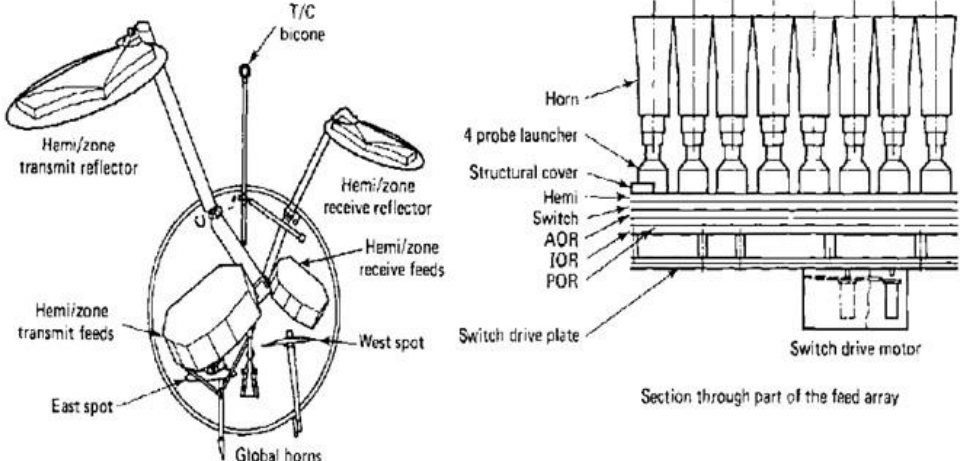
	<p>The bus refers to the vehicle which carries the payload but also to the various subsystems which provide the power, attitude control, orbital control, thermal control, and command and telemetry functions required to service the payload.</p>
<p>31</p>	<p>Draw the block diagram of antenna subsystem. (Apr/May 2021)</p> 

UNIT-II / PART-B

<p>1</p>	<p>Explain about spinning satellite stabilization and momentum wheel stabilization (or) Explain how altitude and orbit control is achieved from a earth station. (or) Explain in detail with necessary schematics the spin stabilization technique and momentum wheel stabilization technique to keep satellites attitude control. (Nov/Dec 2017)</p>
<p>2</p>	<p>Examine how the attitude and orbit control system (AOCS) is achieved through spin stabilization system? Give necessary diagrams. (Nov/Dec 2019)</p>
<p>3</p>	<p>(i) For a satellite circuit the carrier-to-ratio are : uplink 23 dB, downlink 20 dB, intermodulation noise 24dB. Calculate the overall carrier-to-ratio in dBs. Suggest a method to reduce intermodulation noise. (ii) Discuss about the system reliability and design lifetime of the space segment. (Apr/May 2016)</p>
<p>4</p>	<p>i) Justify the reasons behind why the transponders are connected in the communication channel with a neat diagram. (Nov/Dec 2016). ii) Analyze the wideband receiver and input de-multiplexer with appropriate diagrams.</p>
<p>5</p>	<p>From the calculation of system noise temperature prove that C/N ratio is directly proportional to G/T ratio. (Apr/May 2014)&(Nov/Dec 2013)</p>
<p>6</p>	<p>What are the various elements used in the space segments of a satellite system? Explain the need and function of each element in the satellite system. (Nov/Dec 2013)</p>
<p>7</p>	<p>What are the factors contributing to noise in earth station receiving channel? (or) Briefly explain the sources of noise in satellite communication. What is the importance of noise temperature in link design? (Apr/May 2014) & (Nov/Dec 2014)</p>
<p>8</p>	<p>(i) Consider a transmit earth station operating at an uplink frequency of 6 GHz. The antenna diameter is 7 m with efficiency of 60%. The antenna tracking loss and atmospheric attenuation is 1.2dB. The uplink slant range is 37506 km. What is the required output power (dBW) of the HPA system at the antenna feed to provide a 80 dBW/m² power flux density at the satellite? (ii) Write a brief note on the communication payload and supporting subsystems.</p>

	(Apr/May 2016)
9	i) Consider a dual up converter with the following specifications: up link frequency spectrum =14 to 14.5 GHz, First intermediate frequency = 140 MHz, Carrier bandwidth=72 MHz , BPF 1 Centre frequency =1.19 GHz. Determine the first local oscillator frequency, range of second local oscillator frequency, frequency spectrum of unwanted sideband bandwidths of BPF 1 and BPF 2. (ii)With suitable mathematics explain the design aspects of uplink. (Apr/May 2017)
10	What are the three main systems for tracking satellites? How can tracking systems be affected? What are the main functions of TTC subsystem? Explain. (Apr/May 2017)
11	Discuss on the TWTA power amplifier used in a satellite transponder and its power output. (Nov/Dec 2017)
12	Satellite communication employs electromagnetic waves to carry information between ground and space- Justify. (Nov/Dec 2018)
13	The thermal control system represents a common denominator for all operating elements of the spacecraft- Justify. (Nov/Dec 2019)
14	(i) Describe the East West and North South station keeping maneuvers required in satellite station keeping. (ii) Explain what is meant by satellite attitude and briefly describe two forms of attitude control. (Apr/May 2018)
15	. (i) Explain the working of telemetry, tracking and control with a suitable diagram. (ii) Explain what is meant by thermal control and why this is necessary in a satellite. (Apr/May 2018) (Nov/Dec 2019)
16	Determine the angle of tilt required for a polar mount used with an earth station at latitude 49deg north. Assume a spherical earth of radius 6371km and ignore earth station altitude. (Nov/Dec 2019)
17	i) Describe about the cascading of amplifiers. ii) A video signal of bandwidth of 4.2MHz is used to frequency modulate a carrier the deviation ration being 2.56. Calculate the peak deviation and signal bandwidth. iii) Explain the word redundant in redundant earth station and show this diagrammatically. (Nov/Dec 2019)
18	Define and explain the terms roll, pitch and yaw. (Apr/May 2021)
19	Describe the tracking, telemetry and command facilities of a satellite communications system. Are these facilities part of the space segment or part of the ground segment of the system? (Apr/May 2021)
20	Explain Spin Stabilization and Three-axis Stabilization. (Apr/May 2021)
21	Explain what is meant by thermal control and why this is necessary in a satellite. (Apr/May 2021)
22	Explain what is meant by satellite attitude and briefly describe two forms of attitude control. (Apr/May 2021)
UNIT III SATELLITE LINK DESIGN	
Basic link analysis, Interference analysis, Rain induced attenuation and interference, Ionospheric characteristics, Link Design with and without frequency reuse.	
UNIT-III/ PART-A	
1	What are the earth station parameters affecting C/N ratio? (April 2014)

	<p>The earth station parameters affecting C/N ratio are</p> <p>(i)The antenna gain when receiving the wanted transmission</p> <p>(ii) The system noise temperature at the frequency of the transmission.</p>
2	<p>Why is the cassegrain antenna popular for large earth station. (April 2014)</p> <p>The cassegrain antenna is popular due to the following factors,</p> <p>(i)The gain can be increased by approximately 1dB relative to a front fed r by</p> <p>Shaping of the dual reflector system.</p> <p>(ii)Low antenna noise temperature can be achieved by controlling spill over</p>
3	<p>An antenna has a noise temperature of 35K and it is matched into a receiver which has a noise temperature of 100K. Claculate the noise power density and the noise power for a BW of 36MHz. (Nov 2013)</p> <p>$N_0 = (35+100) \times 1.38 \times 10^{-3} = 1.86 \times 10^{-21}$ joules=1</p> <p>$P_N = 1.86 \times 10^{-21} \times 36 \times 10^6 = 0.067$ PW</p>
4	<p>What is terrestrial interface? (Nov 2013)</p> <p>Terrestrial interface is the interconnection with whatever terrestrial system, if any is involved. In the case of small receive only or transmit only stations, the user may be at earth station itself. The data and voice signals are brought together by this interface using either frequency or time division terrestrial multiplex methods.</p>
5	<p>Define antenna gain. (Nov/Dec 2014)</p> <p>The gain of the antenna is the ratio of the maximum radiation to that of the isotropic radiator of the same radius r. Gain, $G = \frac{\psi_M}{\psi_i}$</p>
6	<p>A satellite downlink at 10 GHz operates with a transmit power of 6 W and an antenna gain of 48.2 dB. Calculate the EIRP in dBW. (May/June 2015)</p> <p>$EIRP = 10 \log 6 + 48.2 = 56$ dBW.</p>
7	<p>What is a single carrier per channel (SCPC)?</p> <p>Traffic can be broadly classified as heavy route, medium route, and thin route. In a thin-route circuit, a transponder channel (36 MHz) may be occupied by a number of single carriers, each associated with its own voice circuit. This mode of operation is known as single carrier per channel (SCPC).</p>
8	<p>Write the features of MATV (Nov/Dec 2016)</p> <p>A Master Antenna TV (MATV) system includes,</p> <p>Provide reception of Direct Broadcast System (DBS) TV/FM channels to a small group of users.</p> <p>Single outdoor unit is needed, but feeds number of indoor units.</p> <p>Each receiver has access to all the independent channels of other users.</p>
9	<p>What is outdoor unit?</p> <p>Outdoor unit consists of a receiving antenna feeding directly into a combination of low-noise amplifier/converter. A parabolic reflector is generally used, with the receiving horn mounted at the focus.</p>
10	<p>What is LNB?</p> <p>The receiving horn feeds into a low-noise converter (LNC) or possibly a combination unit consisting of a low-noise amplifier (LNA) followed by a converter. The</p>

	combination is referred to as an LNB, for low-noise block.
11	<p>What is the major difference between DBS TV and conventional?</p> <p>A difference between DBS TV and conventional TV is that with DBS, frequency modulation is used, whereas with conventional TV, amplitude modulation in the form of vestigial single side-band (VSSB) is used.</p>
12	<p>TV transmission may be classified as full transponder or half transponder transmission. State what this means in terms of transponder access. (Apr/May 2016)</p> <p>With most of the communication satellites now in use the ITU objective either cannot be met or can be met only by allocating a complete transponder to a single TV – FM transmission. INTELSAT calls this full transponder TV. Alternatively, one half of the transponder can be used for TV and the other half can be used for other types of transmission.</p>
13	<p>State the reason for the high-power amplifier in earth stations deploying some sort of redundancy configuration. (Apr/May 2016)</p> <p>Reliability is of utmost importance in satellite communications. When a single high-power amplifier is used, transmission will stop upon its failure. Therefore, the high power amplifier in earth station always employs some sort of redundancy configuration.</p>
14	<p>What is the basic form of a cassegrain antenna? (Apr/May 2016)</p> <p>Earth station feed systems most commonly used in satellite communication are Primary feeds, Cassegrain & Offset feed. Common Cassegrain type of antenna is a dual assembly of paraboloid main reflector and sub reflector. The feed is located at one of the sub reflectors, which is closer to the main reflector.</p>
15	<p>What is called antenna noise?</p> <p>Antennas operating in the receiving mode introduce noise into the satellite circuit. Noise therefore will be introduced by the satellite receive antenna and the ground station receive antenna.</p>
16	<p>The range between a ground station and a satellite is 42000 km. Calculate the free space loss a frequency of 6 GHz.</p> <p>[Free space loss] = $32.4 + 20 \log 42000 + 20 \log 6000 = 200.4 \text{ dB}$</p>
17	<p>What is EIRP?</p> <p>Equivalent Isotropic Radiated Power (EIRP) is a measure of radiated or transmitted power of an antenna. It can be calculated from the antenna gain & the power fed to the antenna input.</p>
18	<p>What is noise power spectral density? (April/May 2018)</p> <p>Noise power per unit BW is termed the NPS density.</p> <p>$N_0 = P_N/B_N = KT_N$ joules.</p>
19	<p>Define noise factor. (Nov/Dec 2017) (April/May 2021)</p> <p>Noise factor is defined as an alternative way of representing amplifier noise. In defining the noise factor of an amplifier, the source is taken to be at room temperature denoted by T_0 which is usually taken as 290k, hence the output noise from the amplifier is $N_{0,out} = F GKT_0$</p> <p>Where G is available power gain of the amplifier and F is its noise factor.</p>

20	<p>Define saturation flux density.</p> <p>The flux density required at the receiving antenna to produce saturation of TWTA is termed the saturation flux density.</p>
21	<p>The range between a ground station & a satellite is 42000km. Calculate the free space loss a frequency of 6GHZ.</p> <p>(FSL)=$32.4+20\log 42000+20\log 6000 =200.4$ db.</p>
22	<p>An antenna has a noise temperature of 35k & its matched into a receiver which has a noise temp of 100k. Calculate the noise power density & the noise power for a BW of 36MHZ.</p> <p>$N_0=(35+100) \times 1.38 \times 10^{-23} = 1.86 \times 10^{-21}$ J</p> <p>$PN = 1.86 \times 10^{-21} \text{J} * 36 * 10^6 = 0.067$ PW</p>
23	<p>What is TWTA?</p> <p>TWTA means Traveling Wave Tube Amplifier. The TWTA is widely used in transponder to provide the final output power required to the transducer and its power supplies.</p>
24	<p>What is polarization interleaving?</p> <p>Overlap occurs between channels, but these are alternatively polarized left hand circular and right hand circular to reduce interference to acceptable levels. This is referred to as polarization interleaving.</p>
25	<p>What are factors contributing to noise in an earth station receiving channel? (Apr/May 2017)</p> <p>The factors are Gain / Noise Temperature (G/T ratio), EIRP, Noise factor and Noise figure.</p>
26	<p>List the ionospheric effects on space link.</p> <p>The various the ionospheric effects on space link are:</p> <ul style="list-style-type: none"> ❖ Ionization through solar radiation ❖ Solar activity cycle ❖ Scintillation(high turbulence) after sunset ❖ Traveling Ionospheric Disturbances (TIDs)
27	<p>What is MATV and state its purpose? (Apr/May 2018)</p> <p>A master antenna TV (MATV) system is used to provide reception of DBS TV/FM channels to a small group of users. A MATV system enables TV and FM signals to be distributed to a large number of TV receivers, as opposed to individual antennas for each TV.</p>
28	<p>A receiving system has antenna noise temperature of 60K & its receiver noise figure 9dB. Find the system noise temperature if room temperature is 290K. (Nov/Dec 2019)</p> <p>$T_e = (F-1)T_0$</p> <p>$10\log F=9\text{dB}$</p> <p>$F=7.94$</p> <p>$T_e =(7.94-1)290=2012.6\text{K}$</p>
29	<p>State the basic requirements of an earth station antenna. (Nov/Dec 2019)</p> <p>High gain value</p>

	Narrow beam width and low side lobe level Broadband Low noise temperature Low loss Good rotation capability
UNIT-III / PART-B	
1	a) Draw the block diagram and explain TVRO system b) Explain in detail the test equipment measurement on G/T and C/No. (Nov/Dec2014)
2	a) Explain the earth station transmitter and receiver with necessary block diagram. b) Explain CATV in detail with neat diagram. (May/June 2015) &(Nov/Dec 2014)
3	Describe and compare the MATV and the CATV systems (May/June 2015) & (November 2013)
4	Explain about uplink satellite circuit &downlink satellite circuit.
5	With a neat block diagram explain the functional elements of a basic digital earth station and also the main elements of a satellite tracking system. (Apr/May 2016)
6	Summarize the procedures involved in test equipment measurements on G/T, C/N _o and EIRP with reference to the Earth segment (Apr/May 2016) (or)Derive the downlink C/N ratio for the satellite. (Apr/May 2015), (Nov/Dec 2016)
7	a) Explain how intermodulation noise originates in a satellite link and explain how it is reduced? b) Derive the link – power budget equation. (Apr/May 2015), (Nov/Dec 2016)
8	.i)From the calculation of system noise temperature prove that C/N ratio is directly proportional to G/T ratio. ii)Consider the receive side of an earth station. The antenna gain is 65dB, and its noise contribution is 60 K. The waveguide loss is 0. 5dB.Determine the equivalent noise temperature of LNA assuming that the noise contribution by the down converter is negligible and earth station G/T is 40dB/K.(T _o =300K) (Apr/May 2017)
9	With test setup explain the procedure of EIRP and antenna gain measurement.
10	i)Illustrate in detail about the free space transmission. ii)The range between a ground station and a satellite is 42,000 km .Calculate the free space loss at a frequency of 10GHz. (Nov/Dec 2017)
11	Briefly explain in detail the effects of rain in uplink and downlink in satellite communication. (Nov/Dec 2017)
12	State the tropospheric effects on space link. Explain the use of Travelling wave tube amplifier in satellite communication systems. (Nov/Dec 2018).
13	List and explain the steps of Link power Budget analysis for Downlink. (Nov/Dec 2018)
14	. (i) Explain clearly the working of CATV with diagram. (Apr/May 2018) (ii) In a link budget calculation at 12Ghz the free space loss is 20dB, the antenna pointing loss is 1dB and atmospheric absorption is 2dB. The receiver [G/T] is19.5dB/K and the receiver feeder loss is 1dB. The EIRP is 48dBw. Calculate the carrier to noise power spectral density ratio.
15	Explain in detail about Free space transmission losses, feeder losses and misalignment

	losses in space link. (Apr/May 2018) (Nov/Dec 2019).
16	In a link budget calculation at 12GHz, the free space loss is 206dB, the antenna pointing loss is 1dB, and the atmospheric absorption is 2dB. The receiver G/T is 19.5 dB/K, and the receiver feeder losses are 1 dB. The EIRP is 48DBW. Calculate the carrier to noise spectral density ratio. (Nov/Dec 2019)
17	i)What is TVRO and explain briefly the home terminal for DBS TV/FM reception. ii) Derive the power output of earth station HPA. (Nov/Dec 2019)
18	i)An uplink operates at 14GHz, and the flux density required to saturate the transponder is -120dB (W/m ²). The free space loss is 207dB and the other propagation losses amount to 2dB. Calculate the EIRP required for saturation assuming clear sky conditions. Assume RFL is negligible. ii) Draw the basic arrangement for the detection of the unique word. iii)Define EIRP and derive the formula for it in decibels. (Nov/Dec 2019)
19	A certain 6/4 GHz satellite uplink has earth station EIRP is 80 dBW; Earth station satellite distance is 35780 Km; attenuation due to atmospheric factors is 2 dB; satellite antennas aperture efficiency is 0.8; satellite antennas aperture area is 0.5 m ² ; satellite receivers effective noise temperature is 190 K; satellite receivers bandwidth is 20 MHz. Determine the link margin for satisfactory quality of service if the threshold value of received carrier to noise ratio is 25 dB. (Apr/May 2021)
20	A geostationary satellite transmits 5 W of power with an antenna having a gain of 28 dB. The downlink is operated at 4 GHz and the receive antenna is a dish with diameter of 3.6 m. Compute the EIRP transmitted, and the power received by the receiving antenna. Assume the receiver antenna efficiency to be 0.7 and all the other losses to be 2 dB. (Apr/May 2021).
21	Explain what is meant by saturation flux density. The power received by a 1.8 m parabolic antenna at 14 GHz is 250 pW. Calculate the power flux density (a) in W/m ² and (b) in dBW/m ² at the antenna. (Apr/May 2021)
22	Explain what is meant by input backoff. An earth station is required to operate at an [EIRP] of 44 dBW in order to produce saturation of the satellite transponder. If the transponder has to be operated in a 10 dB backoff mode, calculate the new value of [EIRP] required. (5) iii) Two amplifiers are connected in cascade, each having a gain of 10 dB and a noise temperature of 200 K. Calculate (a) the overall gain and (b) the effective noise temperature referred to input. (Apr/May 2021)
UNIT IV SATELLITE ACCESS AND CODING METHODS	
Modulation and Multiplexing: Voice, Data, Video, Analog – digital transmission system, Digital video Broadcast, multiple access: FDMA, TDMA, CDMA, DAMA Assignment Methods, compression – encryption, Coding Schemes.	
UNIT-IV / PART-A	
1	What is a single mode of operation? A transponder channel aboard a satellite may be fully loaded by a single transmission from an earth station. This is referred to as a single access mode of operation.
2	What are the methods of multiple access techniques? FDMA– Frequency Division Multiple Access Techniques

	TDMA – Time Division Multiple Access Techniques	
3	What is CDMA? CDMA – Code Division Multiple Access Techniques In this method, each signal is associated with a particular code that is used to spread the signal in frequency and time.	
4	Give the types of CDMA. Spread spectrum multiple access • Pulse address multiple access	
5	What is a thin route service? Single carrier per channel (SCPC) systems are widely used on lightly loaded routes, this type of service being referred to as a thin route service.	
6	Define postamble. (Nov/Dec 2017) Postamble is used to indicate the end of the time slot. In a certain phase detector system, the phase detector must be allowed time to recover from one burst before the next burst is received by it. This is termed as detector quenching and a time slot is referred to as postamble in TDMA system.	
7	What are the advantages of TDMA over FDMA? (Nov/Dec 2014) TDMA – Time Division Multiple Access Techniques Only one carrier uses the transponder at any one time, and therefore intermodulation products, which results from the non-linear amplification of multiple carriers are absent.	
8	What is preamble? Certain time slots at the beginning of each burst are used to carry timing and synchronizing information. These time slots collectively are referred to as preamble.	
9	Define guard time. Guard time is defined as a time gap between bursts. It is necessary to prevent the bursts from overlapping. The guard time will vary from burst to burst depending on the accuracy with which the various bursts can be positioned within each frame.	
10	What is meant by decoding quenching? In certain phase detection systems, the phase detector must be allowed for some time to recover from one burst before the next burst is received by it. This is known as decoding quenching.	
11	What are the types of digital speech interpolation?(April 2014) Digital time assignment speech interpolation • Speech predictive encoded communication.	
12	Distinguish centrally controlled random access for satellite access from distributed controlled random access. (Apr/May 2016)	
	Centrally controlled random access	Distributed controlled random access
	As individual terminals do not perform the function of channel assignment terminal's cost is low. As centralized control maintains the status of overall system, depending on the traffic load the capacity of the each station can be varied accordingly.	As no unique controller is used, the reliability is good. As each station maintains a database, failure of one station do not affect the other, but at the same time to maintain a database in each terminal of earth station makes the

		terminal cost high.
13	How does the spread spectrum system differ from conventional communication systems? (Nov/Dec 2016)	The spread spectrum system undergo double modulation, First modulation – Carrier and message signal Second Modulation- the resultant signal and PN code sequence, which spreads the spectrum over the available bandwidth.
14	What is a single access? (May/June 2015)	A transponder channel aboard a satellite may be fully loaded by a single transmission from earth station.
15	What is multiple access technique? (May/June 2015)	A transponder can be loaded by a number of carriers. These may originate from a number of earth station may transmit one or more of the carriers. This mode of operation is known as multiple access technique.
16	Define Multiplexing. (April 2014 and Nov/Dec 2014)	Multiplexing is defined as the process of separating the channel transmitted by a single earth station to prevent them from interfering with each other.
17	What is meant by space division multiple access?	The satellite as a whole to be accessed by earth stations widely separated geographically but transmitting on the same frequency that is known as frequency reuse. This method of access known as space division multiple access.
18	What is an error detecting code?	A code which allows for the detection of errors is termed as error detecting code. Examples of this coding techniques are parity coding, cyclic redundancy check technique, Check sum techniques.
19	What are the limitations of FDMA-satellite access?	a. If the traffic in the downlink is much heavier than that in the uplink, then FDMA is relatively inefficient. b. Compared with TDMA, FDMA has less flexibility in reassigning Channels. c. Carrier frequency assignments are hardware controlled.
20	Write about demand assigned TDMA satellite access. (Nov/Dec 2019)	In demand assigned TDMA access, the burst length may be kept constant and the number of bursts per frame used by the given station is varied when the demand is varied.
21	Write about pre-assigned TDMA satellite access. (Nov/Dec 2016)	Example for pre-assigned TDMA is CSC for the SPADE network. CSC can accommodate upto 49 earth stations in the network and 1 reference station. All bursts are of equal length. Each burst contains 128 bits. The bit rate is 128 Kb / s.
22	Write the two basic problem in satellite digital transmission. (April 2014)	(i)It is difficult to convert incoming analog signal into digital form and then back again. (ii)It is not easy to achieve efficient transmission and reception of digital signals.
23	What is the need of reference burst in TDMA? (May/June 2015) (Apr/May 2021)	

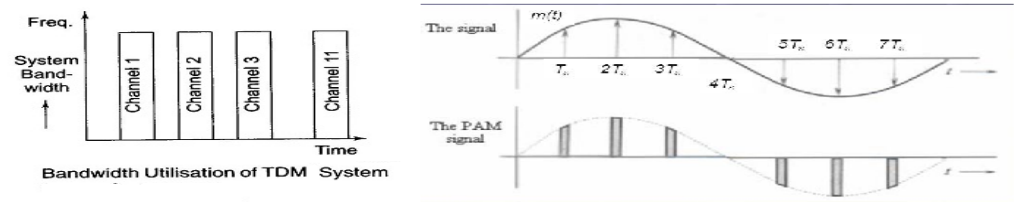
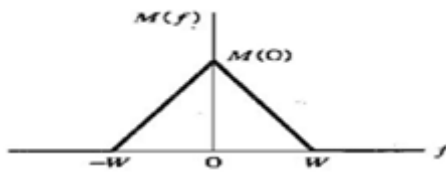
	<p>The reference bursts are transmitted in each frame. The first reference burst is transmitted by the primary reference station for acquisition and synchronization. Second reference burst is transmitted by the secondary station which is used for synchronization purpose.</p>	
24	<p>Distinguish between pre-assigned and demand assigned traffic (November 2013)</p>	
	<p>Pre-assigned</p>	<p>Demand assigned</p>
	<p>Example for pre-assigned TDMA is CSC for the SPADE network. CSC can accommodate upto 49 earth stations in the network and 1 reference station. All bursts are of equal length. Each burst contains 128 bits. The bit rate is 128 Kb / s.</p>	<p>The burst length may be kept constant and the number of bursts per frame used by the given station is varied when the demand is varied.</p>
25	<p>Draw the curve for transfer characteristics of TDM. (Apr/May 2017)</p>	
		
26	<p>Draw the spectrum of baseband voice signal. (Apr/May 2017)</p>	
	 <p style="text-align: center;">Spectrum of Baseband Signal</p>	
27	<p>What is single channel per carrier? Or Define SCPC. (Nov/Dec 2017)/(April/May2018)</p>	
	<p>In a thin route circuit, a transponder channel (36 MHz) may be occupied by a number of single carriers, each associated with its own voice circuit. This mode of operation is known as single channel per carrier (SCPC).</p>	
28	<p>List the features of spread spectrum communication (Nov/Dec2018)</p>	
	<p>The spread spectrum is highly resistant to narrowband interference; difficult to intercept; The code is spread across a wide channel in that case even one bit data cannot give access to the complete information.</p>	
29	<p>How does a CDMA receiver function for the purpose of synchronization maintenance and reliable data reconstruction? (Nov/Dec2018)</p>	
	<p>A system and method for communicating information signals is by using spread spectrum communication techniques. PN sequences are constructed that provide orthogonality between the users so that mutual interference will be reduced, allowing higher capacity and better link performance. With orthogonal PN codes, the cross-</p>	

	correlation is zero over a predetermined time interval, resulting in no interference between the orthogonal codes, provided only that the code time frames are time aligned with each other.	
30	Differentiate multiple access from single access. (Apr/May 2018)	
	Single access	Multiple access
	A transponder channel aboard a satellite may be fully loaded by a single transmission from earth station.	A transponder can be loaded by a number of carriers. These may originate from a number of earth station may transmit one or more of the carriers
	Limited Capacity	Increase in Capacity
31	What is the use of control bits in the data frame? (Apr/May 2021) The control field of the data frame consists of 6 bits (of which only the lower 4 are used) that indicate the amount of data in the message.	
32	What is the need for burst position synchronization? Burst synchronization is required to ensure that all bursts arrive at the satellite in their correct time slots. For this purpose, timing markers are provided by the reference bursts, which are tied to a highly stable clock at the reference station and transmitted through the satellite link to the traffic stations.	
UNIT-IV / PART-B		
1	Explain the principle behind spectrum spreading and dispreading and how this is used to minimize interference in a CDMA system (May/June 2015)	
2	Explain congestion forward error correction and slow start.	
3	Compare the features of the various multiple access schemes deployed for satellite access. Compare the salient features of FDMA, TDMA and CDMA. .(Apr/May 2016)	
4	a) Identify the band limited and power limited TWT amplifier operation. (Nov/Dec 2016) b) Explain the operation of digital TASI in TDMA operation (Nov/Dec 2016)	
5	a) Express FDMA in detail and also enumerate the interference in FDMA (Nov/Dec 2016) b) Explain direct sequence spread spectrum communication in details. (Nov/Dec 2016)	
6	Analyze the frequency reuse process and give the metrics of spread spectrum communication. (Apr/May2016)	
7	Explain in detail about compression and encryption techniques used in satellite communication.	
8	Write the design aspects and explain the technical features of TDMA frame structure. (Apr/May 2017)	
9	i) Draw the encoder diagram for the following digital signals- Unipolar, NRZ, Polar NRZ, Manchester, Polar RZ for the digital data 1010111. ii) Write down the advantages of CDMA for satellite networking. (Nov/Dec 2019)	
10	In detail explain about the time division multiplexing and bandwidth requirements in a satellite transmission system. (Nov/Dec 2017)	
11	Explain in detail the Code division multiple access technique and lists its advantages. (Nov/Dec 2017)	

12	Why is CDMA otherwise called spread spectrum communication? How does it differ from FDMA and TDMA? (Nov/Dec 2018)
13	TDMA is a truly digital technology, requiring that all information be converted into bit streams or data packets before transmission to the satellite. - Justify. (Nov/Dec 2018)
14	Explain in detail how carrier recovery is done in TDMA. Describe the concept of multiplexing. What is the advantage of TDMA over FDMA with respect to demand assignment? (Apr/May 2018) (Nov/Dec 2019)
15	(i) Draw the encoder diagram for the following digital signals- Unipolar NRZ, Polar NRZ, Manchester, Polar RZ for the digital data 1010111 (ii) Explain the principle behind CDMA with a diagram and mention any two advantages of CDMA for satellite networking. (Apr/May 2018)
16	Distinguish between preassigned and demand-assigned traffic in relation to a satellite communications network.
17	Given that the IF bandwidth for a 252-channel FM/FDM telephony carrier is 7.52 MHz and that the required [C/N] ratio at the earth station receiver is 13 db. Calculate (a) the [C/T] ratio and (b) the satellite [EIRP] required if the total losses amount to 200 dB and the earth station [G/T] ratio is 37.5 dB/K.
18	Briefly describe the ways in which demand assignment may be carried out in an FDMA network. . (Apr/May 2021)
19	What is the function of: a) the burst-code word and b) the carrier and bit-timing recovery channel in a TDMA burst? (Apr/May 2021)
20	In a TDMA network the reference burst and the preamble each requires 560 bits, and the nominal guard interval between bursts is equivalent to 120 bits. Given that there are eight traffic bursts and one reference burst per frame and the total frame length is equivalent to 40, 800 bits, calculate the frame efficiency. (Apr/May 2021)
UNIT V SATELLITE APPLICATIONS	
INTELSAT Series, INSAT, VSAT, Mobile satellite services: GSM, GPS, INMARSAT, LEO, MEO, Satellite Navigational System. GPS Position Location Principles, Differential GPS, Direct Broadcast satellites (DBS/DTH).	
UNIT-V / PART-A	
1	Give the 3 different types of applications with respect to satellite systems. 1) The largest international system (Intelsat) 2) The domestic satellite system (Dom sat) in U.S. 3) U.S. National oceanographic and atmospheric administrations (NOAA).
2	Write the principle behind DTH and GPS. (Apr/May 2016) Satellites are used to provide the broadcast transmissions It is used to provide direct transmissions into home. The service provided is known as Direct Broadcast Satellite services. Example: Audio, TV and internet services; GPS receivers use a constellation of satellites and ground stations to compute position and time almost anywhere on earth. At any given time, there are at least 24 active satellites orbiting over 12,000 miles above earth. The positions of the satellites are constructed in a way that the sky above your location will always contain at most 12 satellites. The primary purpose of the 12 visible satellites is to transmit information back to earth over radio frequency (ranging from 1.1 to 1.5 GHz).

3	<p>Give the types of satellite services.</p> <p>a. Fixed satellite service b. broadcasting satellite service c. Mobile satellite service d. Navigational satellite services e. Meteorological satellite services.</p>
4	<p>An intelligent VSAT must use what type of networking to permit the maximum utilization of the satellite capacity? (Apr/May 2016)</p> <p>An intelligent VSAT uses DAMA (demand assignment multiple access) networking to permit the maximum utilization of the satellite capacity.</p>
5	<p>What are the applications of Radarsat?</p> <p>a. Shipping and fisheries. Ocean feature mapping c. Oil pollution monitoring d. Iceberg detection e. Crop monitoring.</p>
6	<p>What is ECEF?</p> <p>The geocentric equatorial coordinate system is used with the GPS system. It is called as earth centered, earth fixed coordinate system (ECEF).</p>
7	<p>Define dilution of precision in GPS? (Nov/Dec 2017)</p> <p>Position calculations involve range differences and where the ranges are nearly equal; any error is greatly magnified in the difference. This effect, brought a result of the satellite geometry is defined as dilution of precision.</p>
8	<p>What is PDOP?</p> <p>With the GPS system, dilution of position is taken into account through a factor known as the Position Dilution Of Precision.</p>
9	<p>What is DBS? Name any two services (Nov/Dec 2019)</p> <p>Satellites are used to provide the broadcast transmissions It is used to provide direct transmissions into home. The service provided is known as Direct Broadcast Satellite services. Example: Audio, TV and internet services.</p>
10	<p>Give the frequency range of US DBS systems with high power satellites.</p> <p>a. Uplink frequency range is 17.3 GHz to 17.8 GHz b. Downlink frequency range is 12.2 GHz to 12.7 GHz.</p>
11	<p>Write about bit rates for digital television.</p> <p>It depends on format of the picture. Uncompressed Bit rate = (Number of pixels in a frame) * (Number of pixels per second) * (Number of bits used to encode each pixel)</p>
12	<p>Give the satellite mobile services. Or write down the names of any four mobile satellite services. (Apr/May 2018)</p> <p>a. DBS – Direct Broadcast satellite b. VSATS – Very Small Aperture Terminals c. MSATS – Mobile Satellite Service d. GPS – Global Positioning Systems e. ORBCOMM - Orbital Communications Corporation</p>
13	<p>What is INMARSAT?</p> <p>It is the first global mobile satellite communication system operated at Lband and internationally used by 67 countries for communication between ships and coast so that emergency life saving may be provided. Also, it provides modern communication services to maritime, land mobile, aeronautical and other users.</p>
14	<p>List out the regions covered by INMARSAT. (November 2013)</p> <ul style="list-style-type: none"> • Atlantic Ocean region, east (AOR-E) • Atlantic Ocean region, west (AOR-W)

	<ul style="list-style-type: none"> • Indian ocean region (IOR)\ • Pacific Ocean region (POR).
15	<p>What is INSAT? INSAT – Indian National Satellite System. INSAT is a Indian National Satellite System for telecommunications, broadcasting, meteorology and search and rescue services. It was commissioned in 1983. INSAT was the largest domestic communication system in the Asia-Pacific region.</p>
16	<p>What is GSM? GSM (Global System for Mobile communications: originally from Grouped Special Mobile) is the most popular standard for mobile phones in the world. GSM differs from its predecessors in that both signaling, and speech channels are digital, and thus is considered a second generation (2G) mobile phone system. This has also meant that data communication was easy to build into the system.</p>
17	<p>What is GPRS? General packet radio service (GPRS) is a packet oriented mobile data service available to users of the 2G cellular communication systems global system for mobile communications (GSM), as well as in the 3G systems. In the 2G systems, GPRS provides data rates of 56-114 Kbit/s.</p>
18	<p>Define DAB. DAB - Digital Audio Broadcast. Digital audio broadcasting (DAB), also known as digital radio and high-definition radio, is audio broadcasting in which analog audio is converted into a digital signal and transmitted on an assigned channel in the AM or (more usually) FM frequency range. DAB is said to offer compact disc (CD)- quality audio on the FM (frequency modulation) broadcast band and to offer FM-quality audio on the AM (amplitude modulation) broadcast band.</p>
19	<p>What is DVB? DVB - Digital Video Broadcasting Digital Video Broadcasting (DVB) is a set of standards that define digital broadcasting using existing satellite, cable, and terrestrial infrastructures.</p>
20	<p>What is GRAMSAT? (Nov/Dec 2014) (Nov/Dec 2016) (Nov/Dec 2017) The Gramsat Programme (GP) is an initiative to provide communication networks at the state level connecting the state capital to districts and blocks. The networks provide Computer Connectivity, Data Broadcasting and TV Broadcasting facilities having applications like e-Governance, National Resource Information System (NRIS), Development Information, Tele-conferencing, Disaster Management, Tele-medicine and Distance Education.</p>
21	<p>Write the four kinds of communication that network structure of MSAT can accommodate. (April 2014) Mobile to mobile, Mobile to dispatcher, Mobile to public switched telephone network, Satellite and network control.</p>
22	<p>Write the two areas of satellite communication which are gaining major thrust from leading satellite industry and organization in recent years. (April 2014) MSAT & VSAT.</p>

23	Name the services provided by GSM. (May/June 2015) Telephony services and data services.
24	Outline the three regions to allocate the frequency for satellite services. (Nov/Dec 2016) Region 1: it covers Europe, Africa and Magnolia Region 2: It covers North & South America and Greenland Region 3: It covers Asia, Australia and Southwest Pacific.
25	List the frequency bands assigned for DTH systems. (Apr/May 2017) 1) Ku band– uplink 14 GHz; downlink 10.9-12.75 GHz 2) Operating frequency of DBS as 11.7-12.5GHz.
26	List the basic principle of VSAT networks. (Nov/Dec 2018) (Apr/May 2021) VSAT (Very Small Aperture Terminal) is a satellite communications system that serves home and business users. A VSAT end user needs a box that interfaces between the user's computer and an outside antenna with a transceiver. The transceiver receives or sends a signal to a satellite transponder in the sky. The satellite sends and receives signals from an earth station computer that acts as a hub for the system. Each end user is interconnected with the hub station via the satellite in a star topology. For one end user to communicate with another, each transmission has to first go to the hub station which retransmits it via the satellite to the other end user's VSAT. VSAT handles data, voice, and video signals.
27	In what ways, does a satellite transfer TV signal to the particular consumer? (Nov/Dec 2018) All signals for television, telephone or internet are converted into radio signals and then sent towards the satellite using a transmitting satellite dish. Most satellite dishes are designed to only receive satellite signals, but some are used to send signals to satellites as well.
28	Mention the services of INSAT. (Apr/May 2018) The important services of INSAT are: Television, VSAT, Communication, Tele-education providing education to the poor and needy, Tele-medicine administering medical services from the metros to villages & remote areas.
29	Write any two features of GPS. (Nov/Dec 2019) 1. Real time positioning 2. Timing synchronization
30	What is the difference between active and passive satellites? (Apr/May 2021) Active satellites are a complicated structure having processing equipment called Transponder. A passive satellite only reflects received signals back to earth.
UNIT-V / PART-B	
1	Describe the operation of typical VSAT system. State briefly where VSAT system find widest application. (May/June 2015)
2	Write notes on a) INTELSAT b) E-mail c) BTV & d) DTH (Nov/Dec 2016)
3	Describe the main features and services offered by Mobile Satellite Systems. (Apr/May 2016)
4	Explain the types of INTELSAT satellites with respect to basic space craft characteristics and vehicle type. (April 2014)

5	i) Discuss in detail about GPS satellite services. (Apr/May 2021) ii) Write a detailed note on MPEG compression standards. (Nov/ Dec2019)
6	Explain the RADAR sat and MSAT. Mention the application.
7	Explain about LEO, MEO & GEO. (Nov 2013) (Apr/May 2021)
8	What is meant by INMARSAT? What are the objectives of the GRAMSAT program? What are applications seen for DAB? (Apr/May 2017)
9	i) With block diagram explain the working principle of DBS-TV receiving system. ii) Write an overview on VSAT systems. (Apr/May 2017) (Nov/ Dec2019) (Apr/May 2021)
10	Write short notes on GSM. (Nov/Dec 2017)
11	Describe on the satellite navigational system. (Nov/Dec 2017)
12	(i) Explain the features of Direct to Home Broadcasting Satellite. (Apr/May 2021) (Nov/Dec 2018) (ii) State the features to make satellite communication system advantageous in appropriate applications. (Nov/Dec 2018)
13	How mobile services are used in satellite communication systems? (Nov/Dec 2018)
14	Write the features of digital TV broadcast. List the various factors of home receiver unit. (Nov/Dec 2018)
15	(i) Explain the concept behind DTH. (ii) Write in detail about the features of GPS. (Apr/May 2018)
16	(i) Briefly describe about satellite navigation system (ii) Describe in detail about video conferencing and state its advantages and disadvantages. (Apr/May 2018)
17	Give a detailed note on E-mail. (Nov/ Dec2019)